

Note:
The NDX series of drawings represents non site specific installations of standard equipment and site layouts.

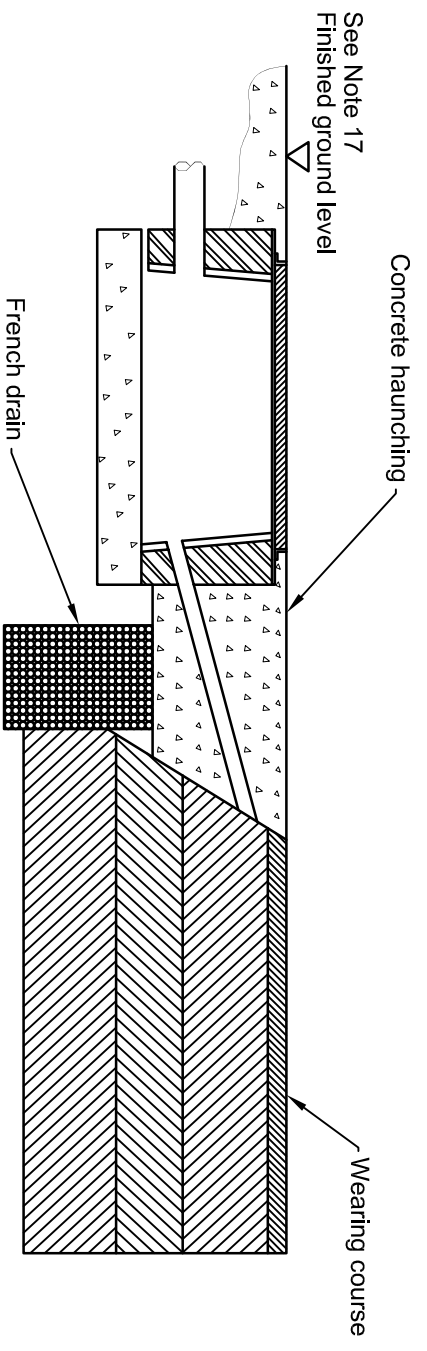
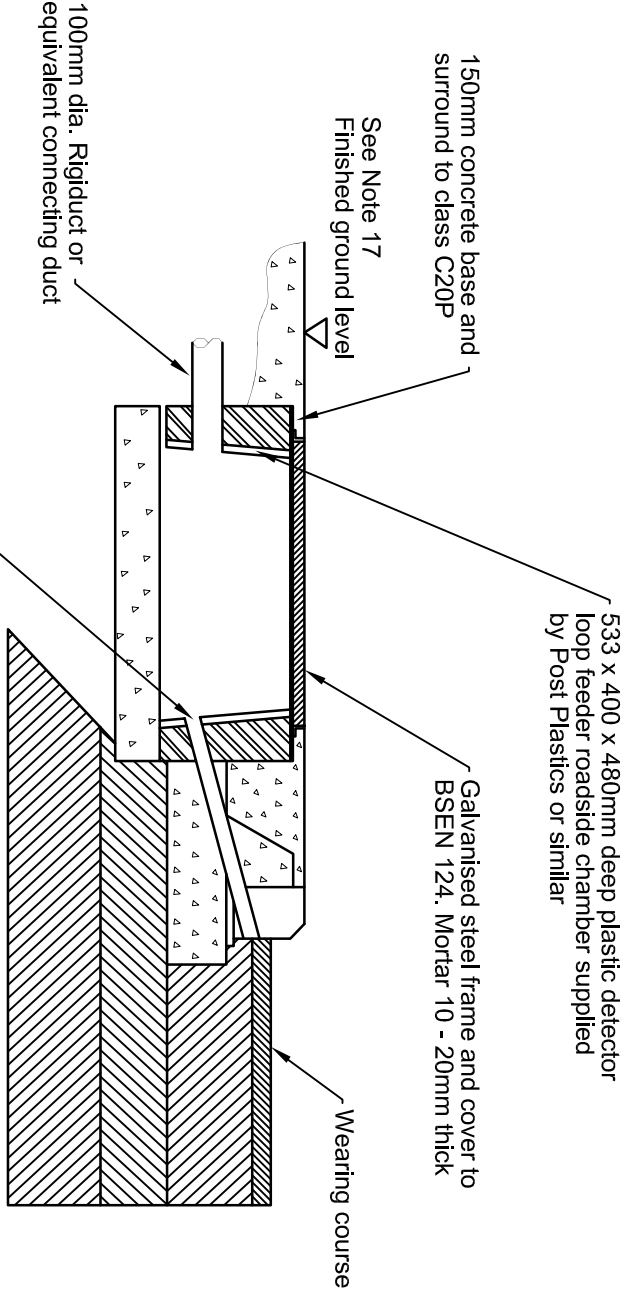

NOTES

1. Roadside chambers shall be installed prior to detector loop slot cutting and installation.
2. Roadside chambers installed with Kerb shall be located in the verge at the kerbline adjacent to the detector loop site as main detail or where no kerbs (French drain installed) the chamber shall be positioned as detail X.
3. Where, for any reason, the roadside chamber cannot be installed adjacent to the proposed loop detector site then it shall be installed at the closest suitable kerbline position to the detector loop site
4. Detector loops shall be installed at the locations shown on the contract drawings and adjacent to previously installed roadside chambers.
5. Refer to the Specification for detector loop details.
6. Where there is a kerb, the cover of the inspection chamber shall be set at kerb level if no kerb set at finished ground level.
7. The feeder cables shall be laid in the inspection chamber with between 0.25M and 0.5M spare.
8. Loop tail grooves shall be separated as detailed in loop layout drawing.
9. Loop circuits shall be identified in the cabinet by labelling the feeders in pairs with appropriate loop identification.
10. On concrete roads care must be taken to avoid cutting near longitudinal joints. Loops shall be cut between traverse joints in the concrete slabs.
11. When loops are required, concrete reinforcement shall be omitted at the design and construction stage.
12. Loop widths may vary to accommodate a different lane width. Refer to loop layout drawings.
13. Loop tails to be twisted together 5 turns/metre.
14. To ensure a close fit between 50mm duct and the loop slot in the wearing course a 45° (approx) 50mm diameter hole should be drilled into the edge of the wearing course to engage the end of the duct.
15. Once the loop tails have been drawn through the duct but prior to sealing the slot with resin/bitumen the duct ends shall be plugged with glass fibre or expanded foam sealant to prevent ingress of resin/bitumen.
16. The installation of loops and associated chamber shall conform to all relevant requirements for the contract - specific reference shall be made to MCH1540 and MCH1589.
17. A concrete apron, with a shallow slope away from chamber cover, shall be constructed for maintenance access. It shall be formed from 150mm minimum deep layer of ST4 concrete with a U2 surface finish. The apron shall be a minimum of 250mm wide and shall extend to the kerb or wearing course on the carriageway side of the chamber.

This drawing was generated on computer and must not be manually updated

TYPICAL TYPE D CHAMBER CONSTRUCTION DETAIL DETECTOR LOOP SITES

ORIGINAL DRAWING SIZE: 297 x 420		DRN	C.S.G.	CHKD	B.D.	SCALE
ALL DIMENSIONS ARE IN MM		DATE	30.04.01	DATE	30.04.01	N.T.S.
TOLERANCE +/- 1 UNLESS OTHERWISE STATED		DRG. NO.	NDX1063-04ga		SHT. NO.	1 of 2
THIRD ANGLE PROJECTION DO NOT SCALE						
C	SEE REVISION SHEET	GC 27/09/06				
B	SEE REVISION SHEET	GC 05/02/06				
D	REDRAWN	BD 13/10/09				
ISSUE		AMENDMENTS		APPD/DATE		