

TITLE OF CABLE CASSETTE TERMINATION ARRANGEMENT IN HA TYPE 609 CABINET

CASSETTE SPLICE HOLDER (SEE NOTE 2)

- NOTES
- 1 CABLE ENTRY HOLES TO BE DRILLED FOR GLAND SIZE No. CES 2 FR 25.5mm FOR GLAND SIZE No. CES 3 FR 35.5mm
 - 2 THE CASSETTE ASSEMBLY MAY BE ROUND TOPPED OR SQUARE (SEE DETAIL 'D')

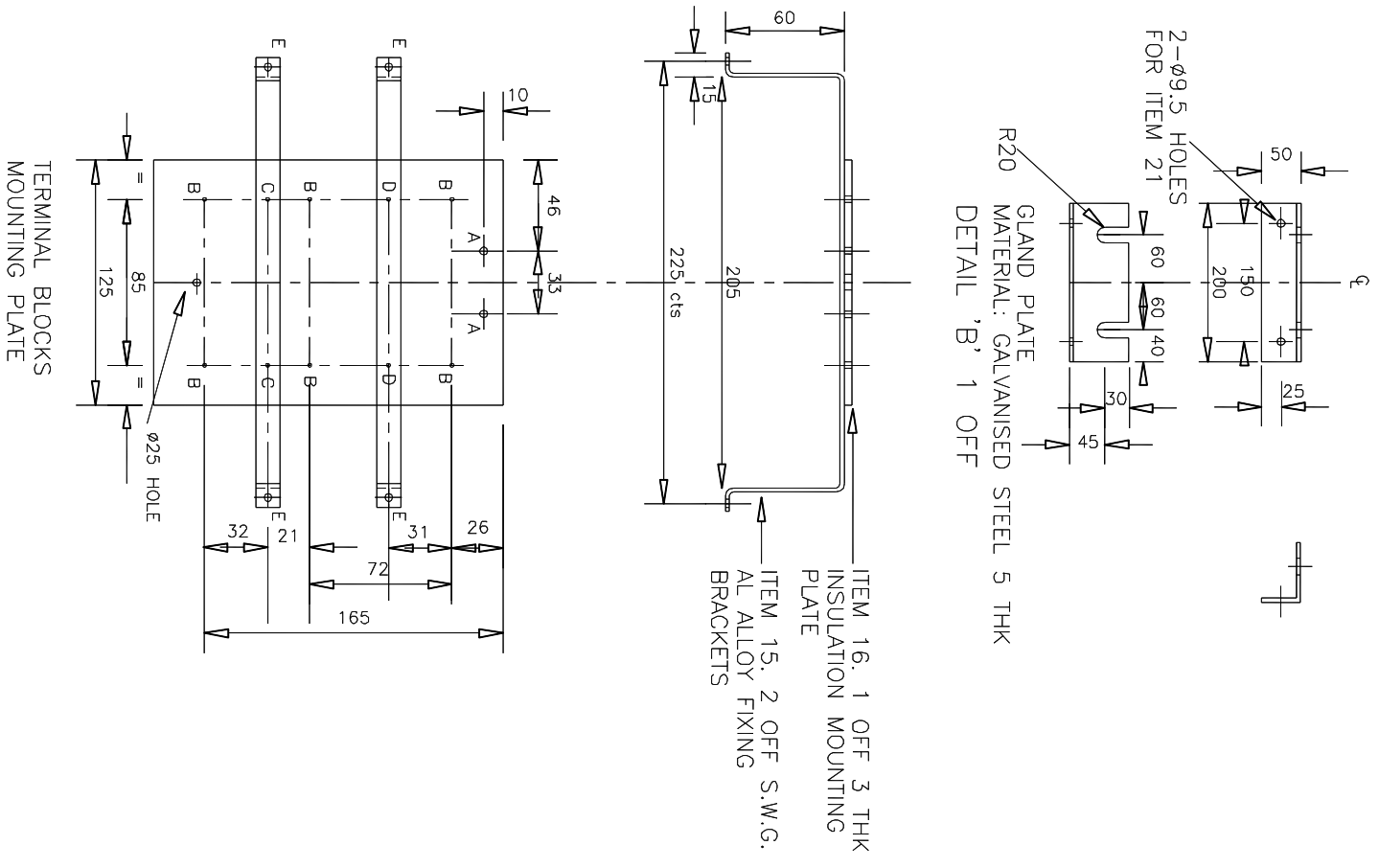
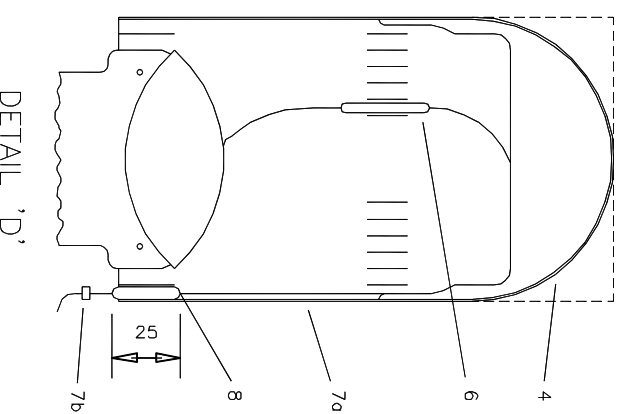
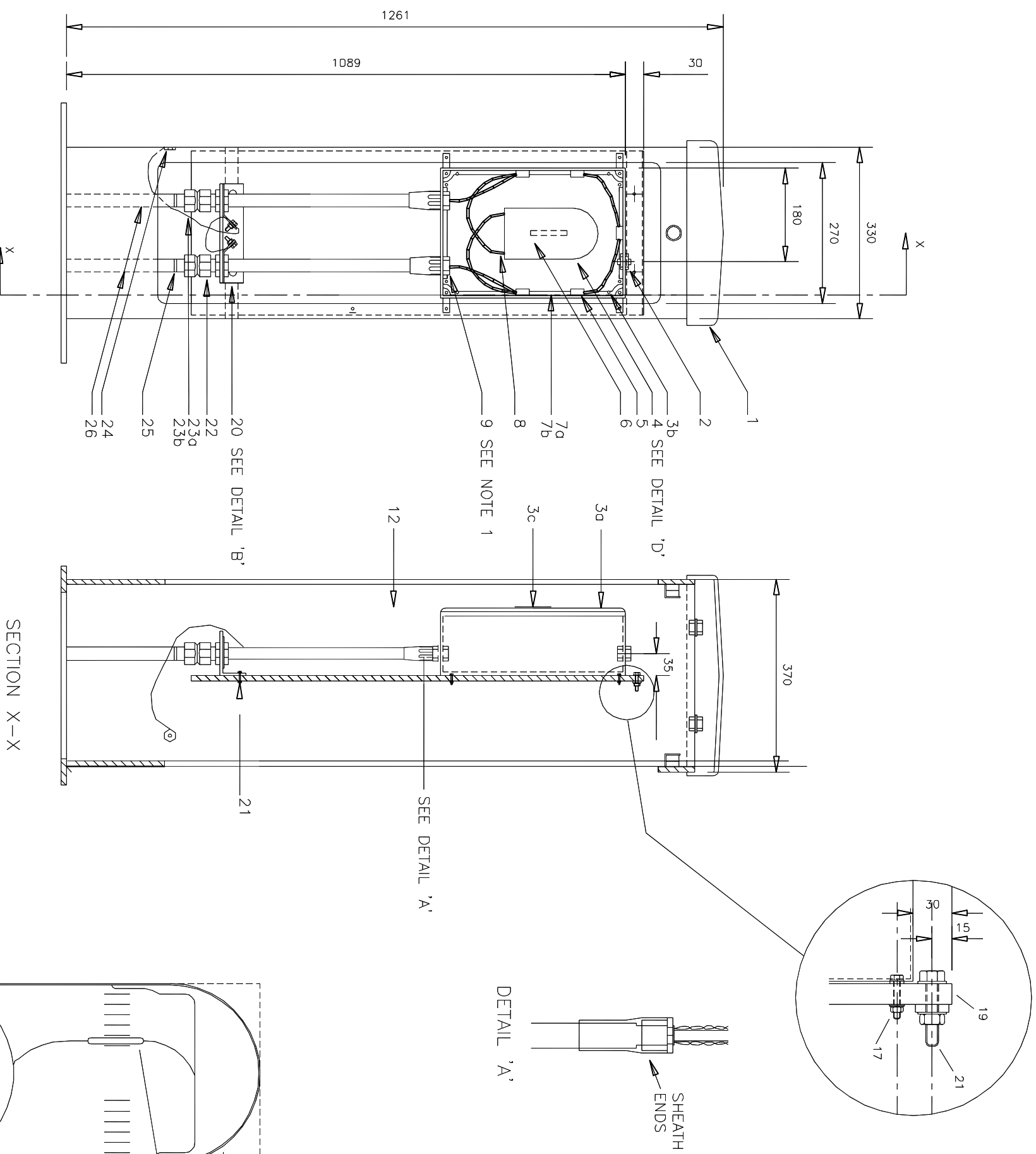

This drawing was generated on computer and must not be manually updated

ORIGINAL DRAWING SIZE: 297 x 420	DRN C.S.G.	CHKD B.D.	SCALE
ALL DIMENSIONS ARE IN MM	DATE 25.09.01	DATE 29.09.01	N.T.S.
TOLERANCE ±1 UNLESS OTHERWISE STATED	DRG. NO. NDX1034-02ga		SHT. NO. 1 of 6
THIRD ANGLE PROJECTION DO NOT SCALE			

ISSUE	AMENDMENTS	APPD/DATE
B	SEE CHANGE SHEET	GC 13.9.2006
A	FOR CONSTRUCTION	BD 09.02.2003
1	FIRST ISSUE	BD 07.12.2001